

Voltage ratings of high power semiconductors

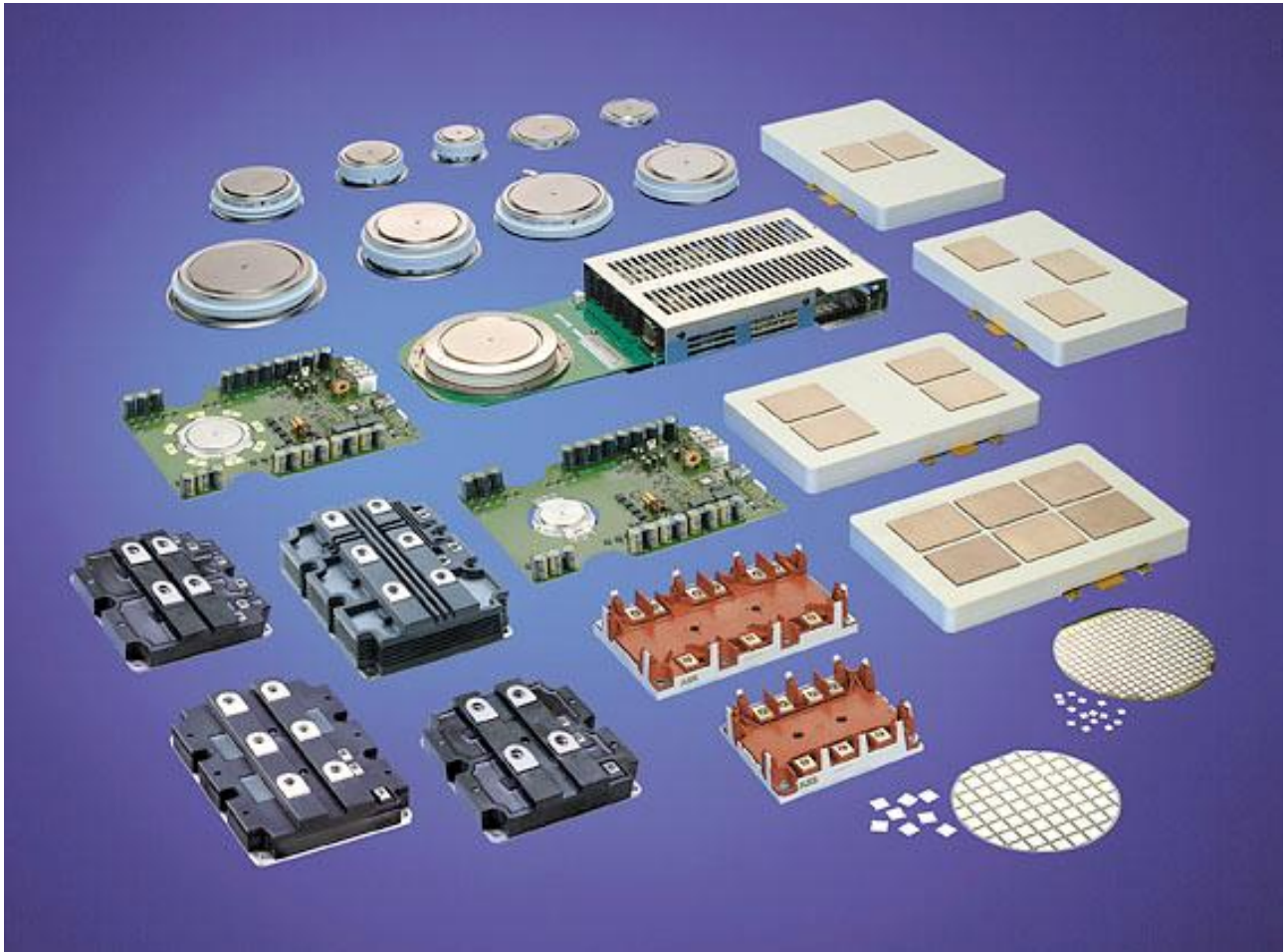

Voltage ratings of high power semiconductors

Product Information

Björn Backlund, Eric Carroll

ABB Switzerland Ltd

Semiconductors

August 2006

Table of Contents:

1	INTRODUCTION.....	3
1.1	PARAMETER DEFINITIONS	3
1.2	COMMENTS TO THE PARAMETER DEFINITIONS.....	4
1.3	CONTROLLED AND UNCONTROLLED ENVIRONMENTS	4
2	DESIGN RECOMMENDATIONS FOR LINE-SIDE HIGH POWER SEMICONDUCTORS	4
2.1	DETERMINING THE REQUIRED VOLTAGE RATING	4
2.2	COMMENTS ON THE SAFETY FACTOR “K”	6
3	DESIGN RECOMMENDATIONS FOR INVERTER-SIDE HIGH POWER SEMICONDUCTORS.....	7
3.1	THE BASIC CONFIGURATIONS	7
3.2	VOLTAGE SOURCE 2-LEVEL INVERTER	9
3.3	VOLTAGE SOURCE 3-LEVEL INVERTER	9
3.4	CURRENT SOURCE INVERTERS	10
3.5	VOLTAGE RATINGS FOR ACTIVE FRONT-END CONVERTERS.....	10
4	ADDITIONAL NOTES	11
4.1	REFERENCES.....	11
4.2	APPLICATION SUPPORT.....	11

1 Introduction

Determining the voltage rating of prospective power semiconductors is normally the first step in the design of power electronic equipment. If the rating is too close to the operating voltage, the risk of failure will be large, adversely affecting equipment availability. If the voltage rating is chosen with excessive safety margins, overall efficiency and performance will suffer since higher rated devices require thicker silicon which generates higher losses. Supply network conditions and equipment design both determine the prospective voltages to which the semiconductors will be exposed. There are no simple rules covering all applications and the ratings have to be determined case by case. This Application Note serves as a guide for voltage selection by collating various recommendations for the most common converter types based on years of experience from the field of power electronics.

These recommendations are for single devices only. The complexity introduced by series connection of devices is not within the scope of this application note.

1.1 Parameter definitions

Several blocking voltages are defined in the data sheets of high power semiconductor. The differences between the various ratings are explained in this section. The definitions are, of course, standardised and can be found in various international standards such as IEC 60747.

It is important to distinguish between repetitive over-voltages V_{DR}/V_{RR} (commutation over-voltages that appear at line frequency) and non-repetitive over-voltage surges V_{DS}/V_{RS} that appear randomly (e.g. because of lightning and network transients). Too high a single voltage surge will lead to an avalanche break-down of the semiconductor and too high a repetitive voltage peak may lead to thermal "runaway" even if the voltage level of these repetitive voltages is below the avalanche break-down limit. DC-voltages stress semiconductors in different ways and will be explained later.

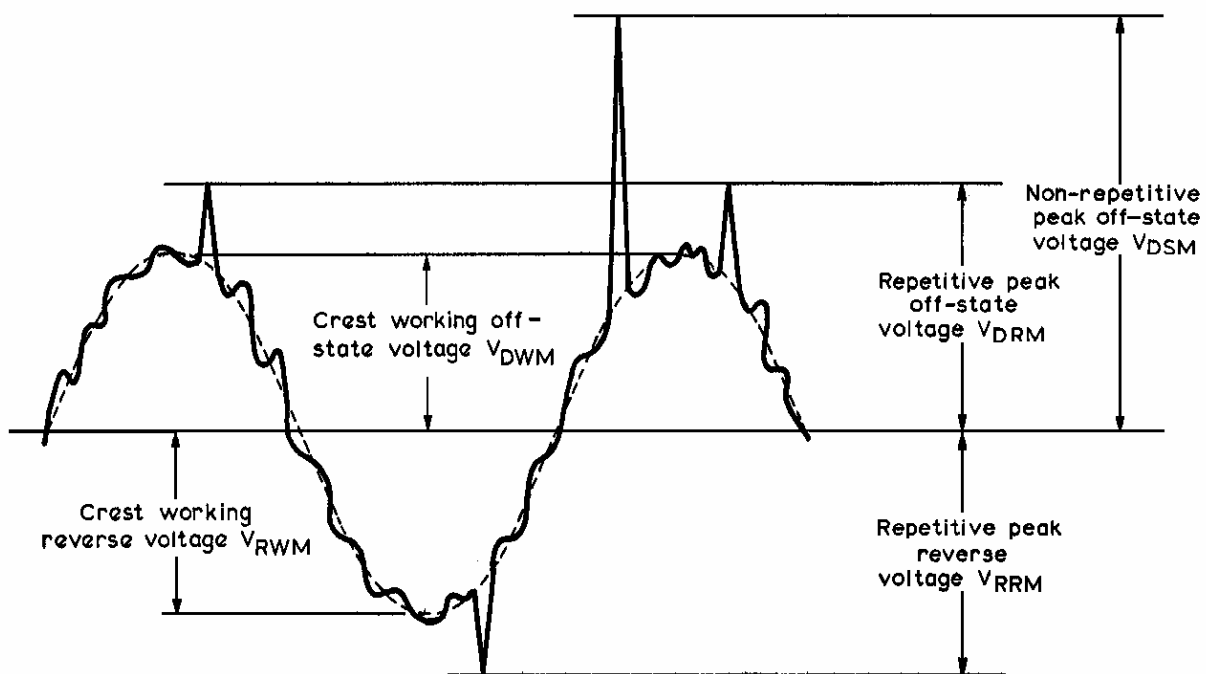

Fig. 1 — Definition of repetitive, non-repetitive and normal operating voltages

V_{DWM} , V_{RWM} : *Maximum crest working forward and reverse voltages.* This is the maximum working voltage at line frequency (Fig. 1).

V_{DSM} , V_{RSM} : *Maximum surge peak forward and reverse blocking voltage.* This is the absolute maximum single-pulse voltage that the devices can instantaneously block. If a voltage spike above this level is applied, the semiconductor will fail. ABB measures this parameter with 10 ms half-sine pulses and a repetition rate of 5 Hz. For safe operation, the device's rated surge peak voltage must be higher than V_{DSM} in Fig. 1.

V_{DRM} , V_{RRM} : *Maximum repetitive peak forward and reverse blocking voltage.* This is the maximum voltage that the device can block repetitively. Above this level the device will thermally "run-away" and fail. This parameter is measured with a pulse width and repetition rate defined in the device specification. For safe operation the device rated repetitive peak voltage must be higher than V_{DRM} in Fig. 1

V_D , V_R : *Maximum continuous direct (forward) and reverse blocking voltage.* This is the maximum DC-voltage that can be applied on the device.

$V_{DC-link}$: *Maximum continuous DC voltage for a specified failure rate (100 FIT for example) due to cosmic radiation.* Exceeding this voltage does not immediately lead to device failure, but the probability of a cosmic radiation failure increases exponentially with the applied voltage. For more information see Application Notes 5SYA2042 "Failure rates of HiPak modules due to cosmic rays" and 5SYA2046 "Failure rates of IGBTs due to cosmic rays".

1.2 Comments to the parameter definitions

These definitions and their test methods can be found in IEC 60747-6. Not all the defined parameters are included in manufacturers' data sheets. Notably, V_{DWM}/V_{RWM} is left to the user to decide as a function of the device limiting voltages V_{DSM}/V_{RSM} . This is because, as will be seen in Section 2, line-commuted devices are chosen as a function of the expected line transients rather than as a function of the nominal line voltage. By the same token, DC voltage is also not specified as, again, transient voltages take precedence over DC voltages (e.g. in a rectifier). The opposite is true of inverter devices. In an inverter, the semiconductors are decoupled from the source of random transients (namely the network) by a large filter (capacitor or inductor). Here the working voltage (DC for a Voltage Source Inverter or AC for a Current Source Inverter) is the determining voltage along with the repetitive peak voltages and surge voltages are no longer considered. This is expanded in the next section.

1.3 Controlled and uncontrolled environments

The circuit designer encounters the problem of over-voltages in two different electrical contexts. The first, which may be referred to as a "controlled environment" is one in which a transient is generated within a known piece of equipment and by a specific circuit component, such as a mechanical or solid state switch operating in an inductive circuit. Such transients can be quantified in current, voltage, time and wave-shape by circuit analysis or measurement. In these circumstances the electrical environment is known or "controlled". By contrast, the second case, considered to be an "uncontrolled environment" defies circuit analysis and also, in general, measurement. This is the case of equipments peripheral to large distributed networks such as power grids. Such "infinitely" distributed networks act as vast "aerials" capturing and transmitting electrical disturbances either from lightning strokes, distribution faults or load-switching by other users. The rational choice of semiconductor voltage rating in such environments starts with a statistical knowledge of the transients in the system. It should be noted that IEC 60664 uses the terms "controlled" and "uncontrolled" in a wider sense to differentiate between systems where transients are completely unknown (unprotected, line-operated) and those where they are either known (internally generated) or limited to well defined levels (protected line-operated systems).

2 Design recommendations for line-side high power semiconductors

2.1 Determining the required voltage rating

Due to the over-voltage transients that occur on a supply network, especially in an industrial environment, the power semiconductor must be carefully chosen to handle most over-voltages without the need for expensive external over-voltage protection. For the definitions used, see Fig. 2.

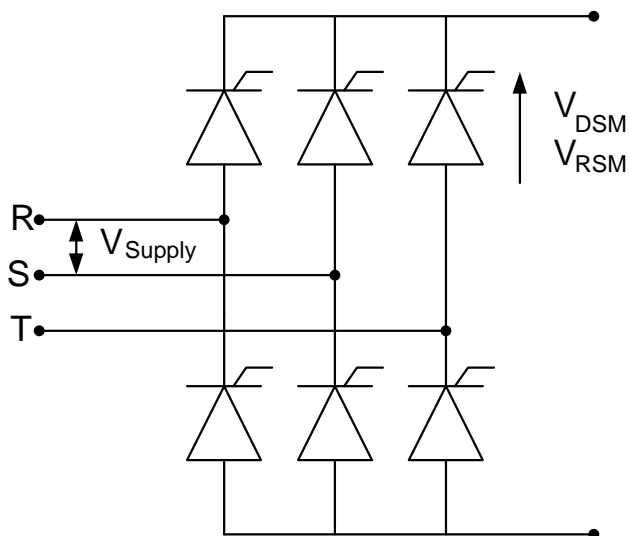

Fig. 2 — Voltage definitions based on the example of a three-phase controlled rectifier

To calculate the required voltage rating Equation 1 is used:

$$V_{DSM} \text{ and / or } V_{RSM} = \sqrt{2} * V_{supply} * k \quad \text{Equation 1}$$

where V_{supply} is the rms-value of the line-to-line supply voltage and k is a safety factor selected according to the quality of the supply network.

There are few publications describing network quality and the values and probabilities of over-voltage spikes. The most comprehensive seems to be IEEE C62.41-1991 “IEEE Recommended Practice on Surge Voltages in Low Voltage AC Power Circuits”, which can be ordered through www.ieee.org. This standard gives surge crest voltages and their probabilities of occurrence for low voltage AC-networks (< 1000V_{RMS}) for different degrees of exposure. Installations within the EU (European Union) must comply with directive 89/336/EEC and related standards (see www.cenelec.org for more information) which require filters for emission suppression. These components also improve over-voltage immunity by attenuating voltage transients from the supply network.

In general network conditions are unknown and so the factor k of Eqn 1 is selected based on experience. For industrial environments, k is normally chosen to be between 2 and 2.5 but for low quality supply networks (and in the absence of over-voltage protection circuits) k may need to be set to a higher value (e.g. $k = 3$). Typically, a high current rectifier supplied by a lightning-protected transformer may be satisfactorily designed with $k = 2.5$ in E^{qn} 1.

By using rectifier devices with controlled avalanche behaviour, normally referred to as “avalanche diodes”, factor k can be reduced since the avalanche diodes will self-protect against certain over-voltage events. A significant reduction of k is not recommended however since the avalanche capability of most semiconductors is limited in terms of energy absorption capability. ABB offers a range of avalanche diodes with 100 % tested avalanche capability of 50 kW or higher for $t_p = 20 \mu s$.

The subject of RC-circuits for thyristors and diodes for reducing commutation voltage transients is not treated here. This subject is covered specifically in Application Note 5SYA 2020 “Design of RC Snubbers for Phase Control Applications”.

Using E^{qn} 1, the preferred voltage ratings for power semiconductors are shown in Table 1 for standard line voltages.

Nominal line voltage	Preferred blocking voltage rating (V_{DSM}/V_{RSM})
400 V_{RMS}	1400
500 V_{RMS}	1800
690 V_{RMS}	2400
800 V_{RMS}	2800
1000 V_{RMS}	3600
1200 V_{RMS}	4200
1500 V_{RMS}	5200
1800 V_{RMS}	6500

Table 1 — Preferred blocking voltage ratings for high power semiconductors operating at standard supply voltages

2.2 Comments on the safety factor “k”

The choice of $k = 2.5$ may appear arbitrary but it must be recognised that it is based on 40 years of experience world-wide. There is little statistical data available on the distribution of transients in Medium Voltage networks but on LV networks, considerable data has been recorded and published in IEEE C62.41-1991. Figs. 3a and 3b are taken from this document and show the distribution of transients in an unprotected system and the surge amplitude dependence on nominal line voltages, respectively.

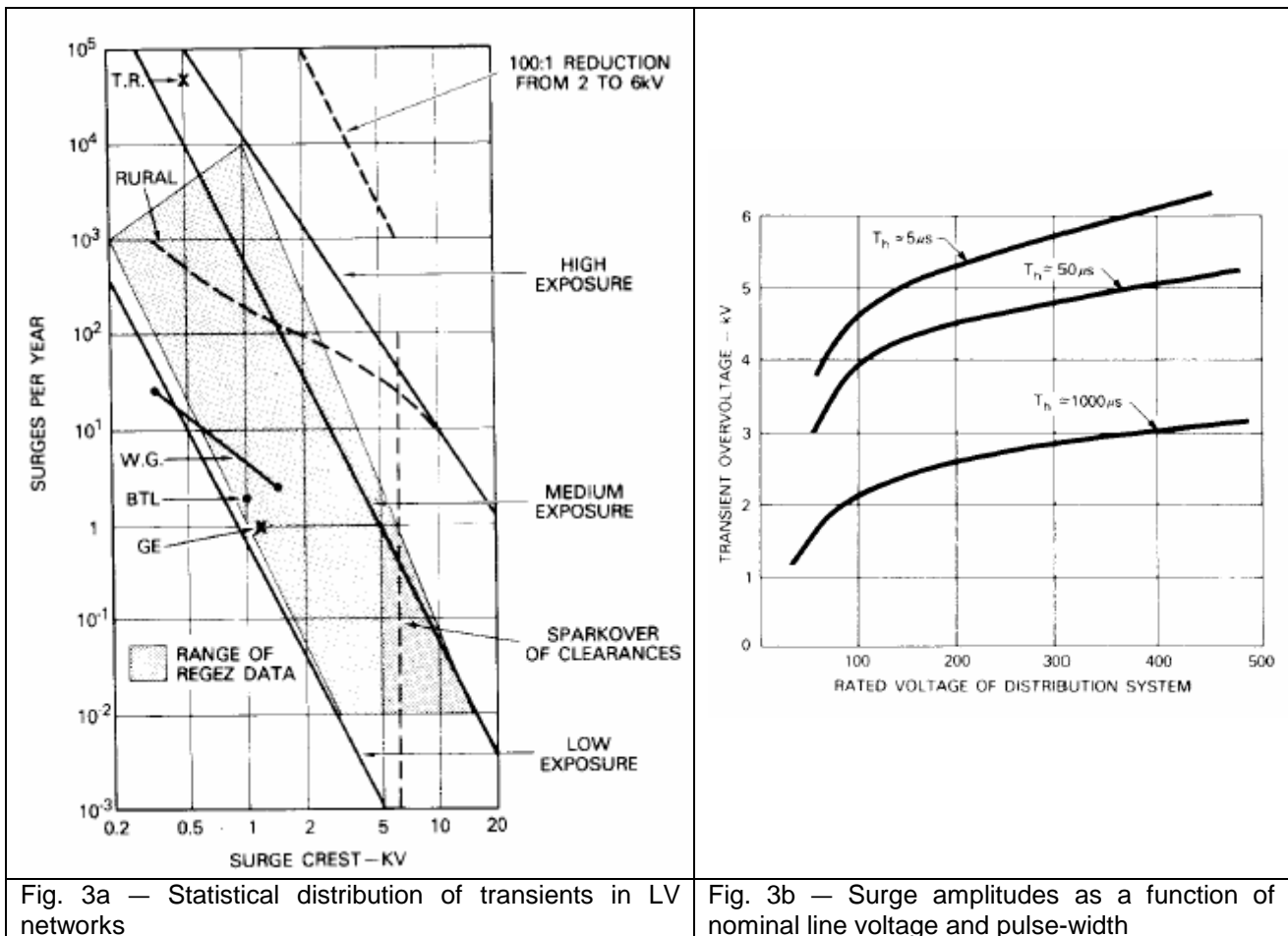

Fig. 3a — Statistical distribution of transients in LV networks

Fig. 3b — Surge amplitudes as a function of nominal line voltage and pulse-width

We observe that transients of amplitude 20 kV may occur in High Exposure environments at the rate of once per year per location in an unprotected system though wiring clearances will normally limit this to 6 kV. An unprotected system is one in which there are no filters, transient absorbers, snubbers or spark gaps (including “accidental” gaps such as wiring clearances in junction boxes). Fig. 3b shows that there is a low sensitivity of transient amplitudes as a function of nominal line voltage. This is because surges within a distribution grid will be transmitted through transformer inter-winding capacitances with little regard for the turns ratios. This implies that Fig. 3a, in the absence of better data, might be applied to Medium Voltage networks. The guide further suggests that the impedance in a High Exposure area is 12 Ω for a fast (5 μ s.) transient and 2 Ω for a slow (50 μ s) transient, which facilitates the design of input filters.

Whereas IEC 60747 allows the manufacturer to determine (and declare) the pulse-widths and repetition rates for the testing of $V_{DRM/RRM}$, and $V_{DSM/RSM}$, it stipulates that $V_{DWM/RWM}$ be tested at line frequency with full sine waves. As already stated however, the working voltages are no longer specified and it has become common practice for the $V_{DRM/RRM}$ of low and medium voltage devices to be tested in the same way as $V_{DWM/RWM}$ in the interest of simplicity. High voltage devices (say >5kV) however, require a return to the original spirit of the International Standards to avoid thermal runaway or a temperature de-rating during testing.

3 Design recommendations for inverter-side high power semiconductors

The voltage ratings for inverter devices are different to those of converters. This is especially true for Voltage Source Inverters (VSI) where a DC-link (capacitor bank) filters out random transients from the uncontrolled environment (grid). This means, as indicated above, that voltage safety margins can be reduced and there is no need for a $V_{DSM/RSM}$ rating. On the other hand, the presence of a continuous DC voltage across the devices leads to a higher probability of cosmic ray failure or of thermal runaway, thus making the DC Working Voltage, the determinant rating.

3.1 The basic configurations

The recommended voltage rating for the active switching element and its free-wheel diode in a VSI, is not only determined by the supply voltage but also by the configuration used for the inverter. In this paragraph we concentrate on the most common inverter types and the recommended ratings for each of them at the most common supply voltages. In Section 3.2 we consider the 2-level voltage source inverter (2-L VSI, see Fig. 4); in Section 3.3, the 3-level voltage source inverter (3-L VSI, see Fig. 5) and finally we look at the current source inverter (CSI, see Fig. 6) in Section 3.4. Other configurations such as multi-level inverters are not included in this application note.

In a VSI, there are three voltage ratings which have to be considered:

- 1) the DC-voltage which determines the cosmic radiation failure rate and long-term leakage current stability
- 2) the repetitive over-voltage spikes at turn-off which must not exceed the rated V_{DRM} of the device
- 3) the maximum voltage against which the device is supposed to switch (a specified) current to guarantee its Safe Operating Area; this voltage may be determined by short-term braking conditions and filter voltage ripple but is considered outside the scope of this application note.

For a good utilisation of the power semiconductor, it is very important to minimise the stray inductance in the switching loop, since a high inductance will lead to a high over-voltage spike requiring a higher V_{DRM} rating for the device. For examples of the influence of the stray inductance see Application Note 5SYA2032 “Applying IGCTs”.

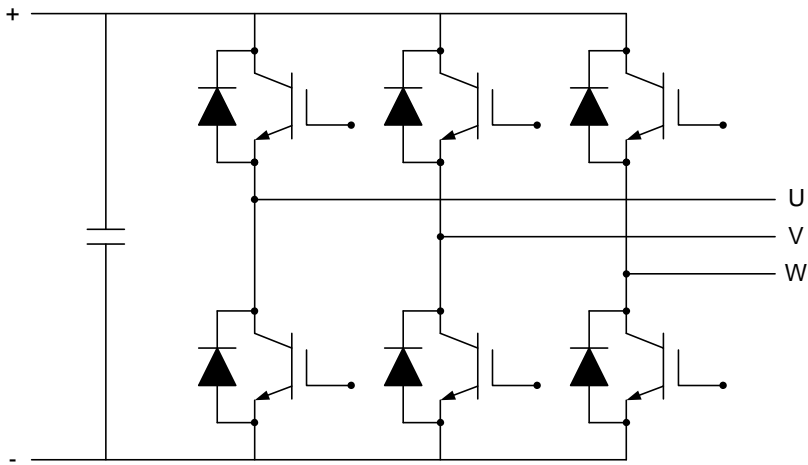

Fig. 4 – 2-level voltage source inverter with IGBTs

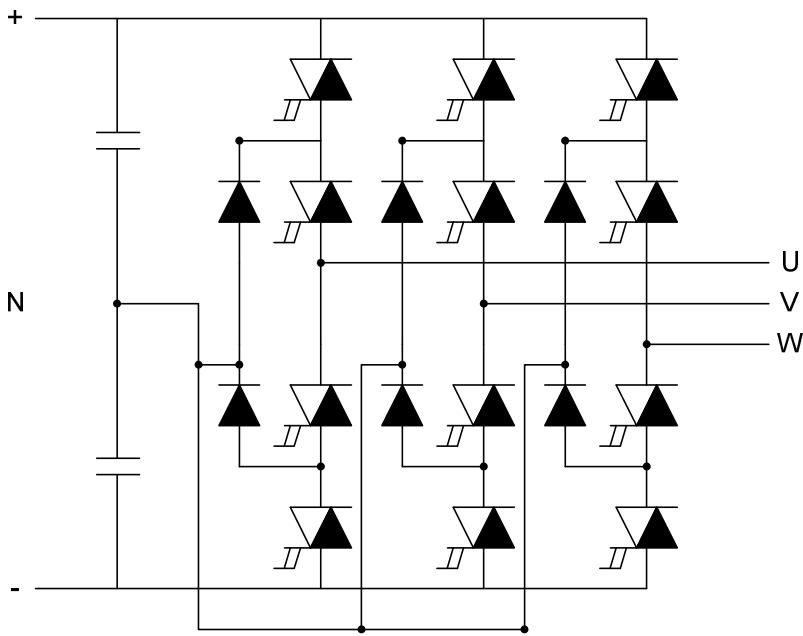

Fig. 5 – 3-level Voltage Source Inverter with reverse conducting IGCTs

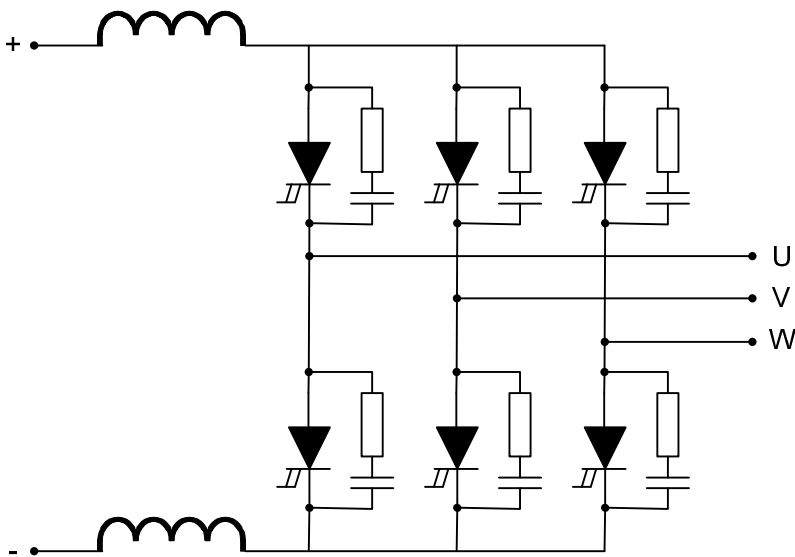

Fig. 6 – Current Source Inverter with reverse blocking IGCTs

3.2 Voltage source 2-level inverter

In this configuration, each semiconductor will see the total DC-voltage. The required DC-voltage as a function of the supply voltage is calculated using E^{qn} 2.

$$V_{DC} = V_{NOMRMS} \times \sqrt{2} \times \left(1 + \frac{x}{100}\right) \quad E^{qn} 2$$

where x is an over voltage factor which depends on the application and corresponds to normal line tolerances. For typical industrial networks, x = 10 % for low voltage systems and x = 15 % for medium voltage systems. For traction lines, typically, x = 20 %.

To calculate the required peak repetitive voltage rating, E^{qn} 3 is used.

$$V_{DR} = V_{DC} \times \left(1 + \frac{y}{100}\right) \quad E^{qn} 3$$

where y is a safety factor that has to be selected based on switching conditions and stray inductances. For the calculation of the required voltage rating, a safety margin of about 50 % is used for low stray inductance inverters and for medium stray inductances, a safety margin of about 60 % is used. The preferred device rating is then normally selected as the next highest standard device voltage rating.

Using E^{qns} 2 and 3, the preferred voltage ratings for the semiconductor at standard line voltages are shown in Table 2.

Nominal line voltage	Nominal DC-link voltage for cosmic ray rating (V)	Preferred repetitive blocking voltage rating (V)
400 V _{RMS}	620	1200
750 V _{DC}	900	1700
690 V _{RMS}	1070	1700
1500 V _{DC}	1800	3300
1700 V _{RMS}	2800	4500
3000 V _{DC}	3600	6000
3300 V _{DC}	4000	6500

Table 2 – Preferred blocking voltage ratings for high power semiconductors used in 2-level VSIs

3.3 Voltage source 3-level inverter

Due to the 3-level connection, each semiconductor will only see half of the total DC-voltage. The required DC-voltage as a function of the supply voltage is calculated using E^{qn} 4.

$$V_{DC} = \frac{V_{NOMRMS} \times \sqrt{2} \times \left(1 + \frac{x}{100}\right)}{2} \quad E^{qn} 4$$

where V_{DC} is the DC-voltage per device and x is an over voltage factor which depends on the application. For industrial networks, typically, x = 15 % and for traction networks, typically, x = 20 %.

To calculate the required repetitive voltage rating, again, E^{qn} 3 is used with a safety margin of about 50% for low stray inductance and 60% for medium stray inductances. The preferred device rating is then normally selected as the next highest standard device voltage rating.

Using E^{qns} 3 and 4, the preferred voltage ratings for the high power semiconductor at standard line voltages are shown in Table 3.

Nominal line voltage	Nominal DC-link voltage for cosmic ray rating (V)	Preferred repetitive blocking voltage rating (V)
2300 V _{RMS}	1900	3300
3300 V _{DC}	2000	3300
3300 V _{RMS}	2700	4500
4160 V _{RMS}	3400	5500
6000 V _{RMS}	4900	8000
6600 V _{RMS}	5400	8500
6900 V _{RMS}	5600	9000
7200 V _{RMS}	5900	9500

Table 3 – Preferred blocking voltage ratings for high power semiconductors used in 3-level VSIs

3.4 Current source inverters

Since a CSI operates at AC rather than DC voltage, the semiconductor voltage ratings are determined differently from those of a VSI. For the cosmic ray withstand voltage, normally the AC-peak voltage over the device is selected. It is calculated using E^{qn} 5.

$$V_{ACpeak} = V_{NOMRMS} \times \sqrt{2} \times \left(1 + \frac{x}{100}\right) \quad E^{qn} 5$$

where x is an over voltage factor that depends on the application. For industrial networks, typically, x = 15 %.

To calculate the required repetitive voltage rating, E^{qn} 6 is used:

$$V_{DR} = V_{ACpeak} \times \left(1 + \frac{y}{100}\right) \quad E^{qn} 6$$

where y is a safety factor that has to be selected based on switching conditions and stray inductances. For high stray inductances the safety margin is typically 70 %. The preferred device rating is then normally selected as the next highest standard device voltage rating.

Using E^{qns} 5 and 6, the preferred voltage ratings for the high power semiconductor at standard line voltages are calculated in Table 4.

Nominal line voltage	Nominal AC peak voltage for cosmic ray rating (V)	Preferred repetitive blocking voltage rating (V)
2300 V _{RMS}	3700	6500
3300 V _{RMS}	5400	9000

Table 4 – Preferred blocking voltage ratings for high power semiconductors used in CSIs

3.5 Voltage ratings for active front-end converters

It is increasingly the case that inverter devices are used in converters for Active Front-End rectification. This implies that inverter devices might also have to be specified in the same way as converter thyristors, e.g. with a V_{DSM/RSM} rating. This is currently not the case since Turn-of Devices (ToDs such as IGCTs, IGBTs and GTOs), being significantly more costly than thyristors, tend to be fitted with adequate protection such as filters and continue to be perceived as operating in the Controlled Environment. This being the case, symmetric (reverse blocking) devices such as RB-IGCTs (or “SGCTs”) will ultimately need a return to the V_{DWM/RWM} rating as a clear specification of their blocking stability and cosmic ray withstand capability in the same way that asymmetric devices have DC voltage ratings.

4 Additional notes

4.1 References

- 1) IEC 60664-1 (1992) "Insulation Co-ordination Within Low-Voltage Systems"
- 2) IEC 60747 "Semiconductor Devices"
- 3) IEEE C62.41-1991 "IEEE Recommended Practice on Surge Voltages in Low Voltage AC Power Circuits"
- 4) 5SYA2020 "Design of RC Snubbers for Phase Control Applications"
- 5) 5SYA2032 "Applying IGCT's"
- 6) 5SYA2042 "Failure rate of HiPak modules due to cosmic rays"
- 7) 5SYA2046 "Failure rates of IGCTs due to cosmic rays"

4.2 Application support

For further information please contact:

Product Marketing Engineer:

Björn Backlund

Phone +41 58 586 1330, fax +41 58 586 1306

e-mail bjorn.backlund@ch.abb.com

Address:

ABB Switzerland Ltd

Semiconductors

Fabrikstrasse 3

CH-5600 Lenzburg

Switzerland

Tel: +41 58 586 1419

Fax: +41 58 586 1306

E-Mail abbsem@ch.abb.com

Internet www.abb.com/semiconductors

Data sheets for the devices and your nearest sales office can be found at the ABB Switzerland Ltd, Semiconductors internet web site:

[http:// www.abb.com/semiconductors](http://www.abb.com/semiconductors)