

# Design of RC Snubbers for Phase Control Applications

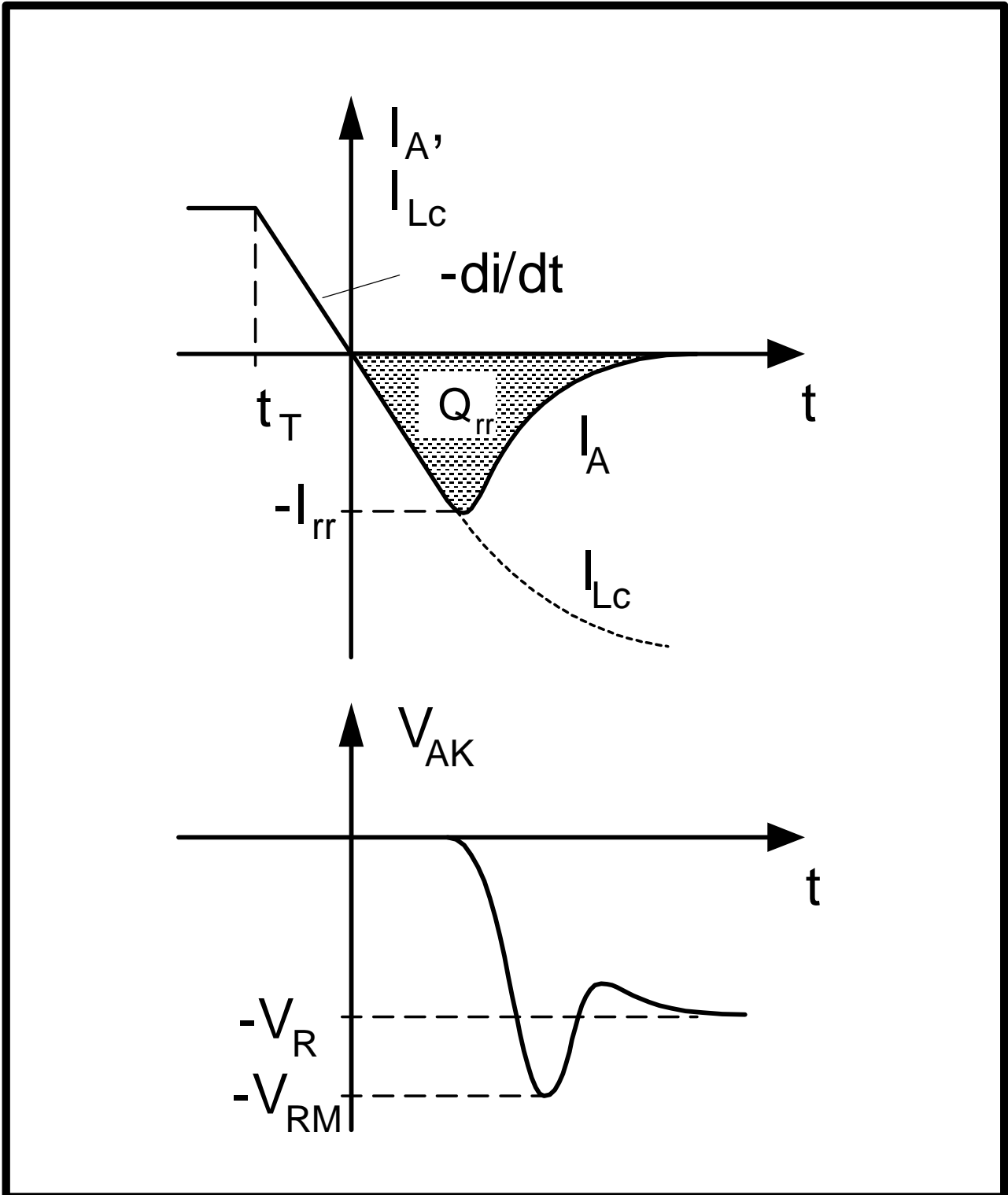

---

# Design of RC Snubbers for Phase Control Applications

## Application Note

Jürg Waldmeyer, Björn Backlund

ABB Switzerland Ltd

Semiconductors

February 2008

### Table of Contents:

<b>1</b>	<b>DESIGN OF RC SNUBBERS FOR PHASE CONTROL APPLICATIONS.....</b>	<b>3</b>
1.1	INTRODUCTION .....	3
<b>2</b>	<b>DEVICE TURN-OFF PROCESS .....</b>	<b>3</b>
<b>3</b>	<b>MODELS FOR REVERSE RECOVERY CURRENT .....</b>	<b>5</b>
3.1	EXPONENTIAL RECOVERY CURRENT MODEL.....	6
3.2	HYPERBOLIC SECANT RECOVERY CURRENT MODEL.....	6
3.3	CALCULATION OF REVERSE OVERVOLTAGE PEAK .....	7
<b>4</b>	<b>SNUBBER DESIGN FOR AN INDIVIDUAL SEMICONDUCTOR.....</b>	<b>9</b>
<b>5</b>	<b>SNUBBER ACTION IN 6-PULSE CONVERTER BRIDGE CONFIGURATION .....</b>	<b>9</b>
<b>6</b>	<b>SNUBBER COMPONENT SELECTION .....</b>	<b>11</b>
6.1	VOLTAGE RATINGS OF SNUBBER CAPACITOR AND SNUBBER RESISTOR.....	11
6.2	POWER RATING OF SNUBBER RESISTOR .....	12
<b>7</b>	<b>CONCLUSIONS .....</b>	<b>13</b>
<b>8</b>	<b>ADDITIONAL NOTES .....</b>	<b>13</b>
8.1	REFERENCES.....	13
8.2	APPLICATION SUPPORT.....	14

---

# 1 Design of RC Snubbers for Phase Control Applications

## 1.1 Introduction

Semiconductor devices are known to be very powerful in controlling high currents and voltages. Nevertheless, they are very susceptible to violations of the safe-operating conditions which may lead to their failure. When a phase control device has to turn off its current under inductive load conditions, it is very important that the voltage between anode and cathode remains inside the acceptable voltage limits. Although a semiconductor device acts as a capacitor with its in-built junction capacitance when the reverse voltage starts to build up during turn-off, an additional parallel RC snubber branch normally has to be utilized to further reduce the overvoltage to a reasonable limit. Obviously, the design of the snubber components depends on the operating conditions (commutation inductance, commutation voltage and thus  $di/dt$  during turn-off) and on the semiconductor component itself (reverse current waveform under the given operation and circuit conditions). As a consequence, the snubber also has an influence on the turn-off loss in the semiconductor component. It is the purpose of the present application note to summarize the turn-off process of phase control devices and to present a design procedure for an optimized snubber in a specific application. For a given turn-off voltage and a given component voltage limit, the optimization will lead to minimum snubber capacitance, which normally also approximates the minimum in cost, space and power loss.

Series connection of phase controlled devices is not treated in this application note; in such a case control of transient voltage sharing homogeneity has to be investigated additionally. The following considerations can be used for rectifier diodes and phase control thyristors. Due to the assumption of soft recovery made on reverse recovery current waveforms, the evaluations may not be as appropriate for fast switching devices with heavy particle irradiation, and obviously they are not useful at all for turn-off devices such as IGBTs, IGCTs and GTOs in their normal operation modes, in which the current and voltage transients differ considerably from the situation described here

## 2 Device Turn-Off Process

The typical equivalent circuit defining the turn-off transient for a phase control device (phase control thyristor in this case) is given in Fig. 1. In the initial phase ( $t \leq 0$ ) the switch  $S_1$  is in position (a), and the forward current  $I_A = I_T$  flows through the PCT in the on-state. The snubber current  $I_s$  is zero, and the snubber capacitor  $C_s$  is uncharged. At  $t = t_T$ ,  $S_1$  is moved to position (b). The anode current now starts to decrease with  $di/dt = -V_R/L_c$ , as can be seen in Fig. 2 (a). This condition continues even when the anode current reverses, because the semiconductor component still has a high amount of charge remaining for a few tens of microseconds and is able to conduct current. Now, the semiconductor stops conducting, and due to the commutation inductance (needed to limit  $di/dt$  in the semiconductor) the semiconductor voltage tends to jump to  $V_R$  and to overshoot. The snubber branch ( $R_s, C_s$ ) now serves to reduce this overvoltage by conducting the current  $I_s = I_{Lc} - I_A$  for a limited time itself, thereby charging  $C_s$ . This reduces the overvoltage (and  $dv/dt$ ), and it obviously also reduces the energy loss in the semiconductor (because the momentary power is reduced), but it stores energy in the snubber capacitor. This energy has to be dissipated later in the snubber resistor when the semiconductor turns on again or when the voltage returns to zero for other reasons.

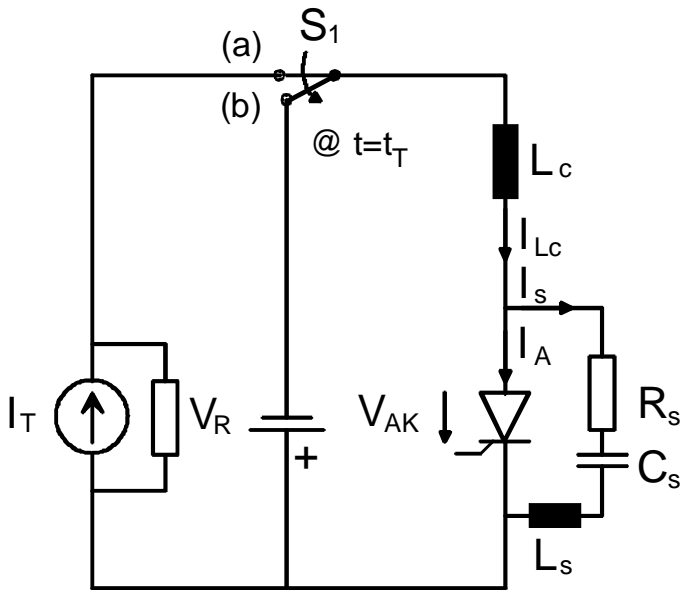

Fig. 1 Equivalent circuit for turn-off of a rectifier diode or a phase control thyristor

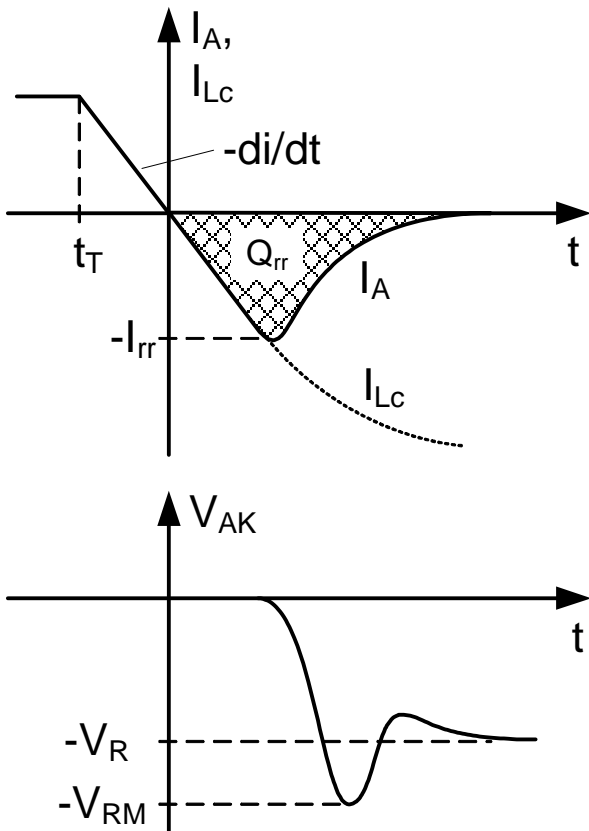

Fig. 2 Current and voltage transients in a turn-off process according to Fig. 1

For a given semiconductor component, the reverse recovery current  $I_{rr}$  and the reverse recovery charge  $Q_{rr}$  are strongly dependent on  $di/dt$  and junction temperature. These values are specified based on the condition that the device is in a stationary conducting state before the turn-off process starts. Their own dependence on the snubber is small and can normally be disregarded. The dependence on  $I_T$  is virtually zero if the  $di/dt$  is small enough to make the forward-current decay phase quasi-stationary, i.e. if  $I_T / di/dt$  is at least a few times the carrier lifetime (typically a few hundred microseconds). Since the snubber capacitor has to integrate up the current difference  $I_s = I_{Lc} - I_A$ , the overvoltage is a function of the recovery waveform of the semiconductor device for a given circuit configuration. Different waveforms with equal  $I_{rr}$  and  $Q_{rr}$  will lead to somewhat different overvoltage peak values, and this is the point where it becomes interesting to find an appropriate model for the reverse recovery current as a function of time.

In the present application note, the initial current decay slope " $di/dt$ ", which is mathematically negative because the positive current decreases, will as a simplification be used as a positive quantity in the formulas used.

### 3 Models for Reverse Recovery Current

It is known that due to different device designs, the reverse recovery current waveform can have different shapes. We traditionally distinguish between soft and hard recovery, and an extreme case is snap-off, as is shown in Fig. 3 (a). Snap-off is generally not desired, since it often leads to excessive overvoltages and induces ringing of the circuit. The type of recovery can be described by a *softness factor*  $s$ , defined as  $s = (t_{rr} - t_a)/t_a$ , where  $t_{rr}$  is given by a straight line through the reverse recovery current peak and the point at  $-0.25 I_{rr}$  on the decaying part of the recovery curve.

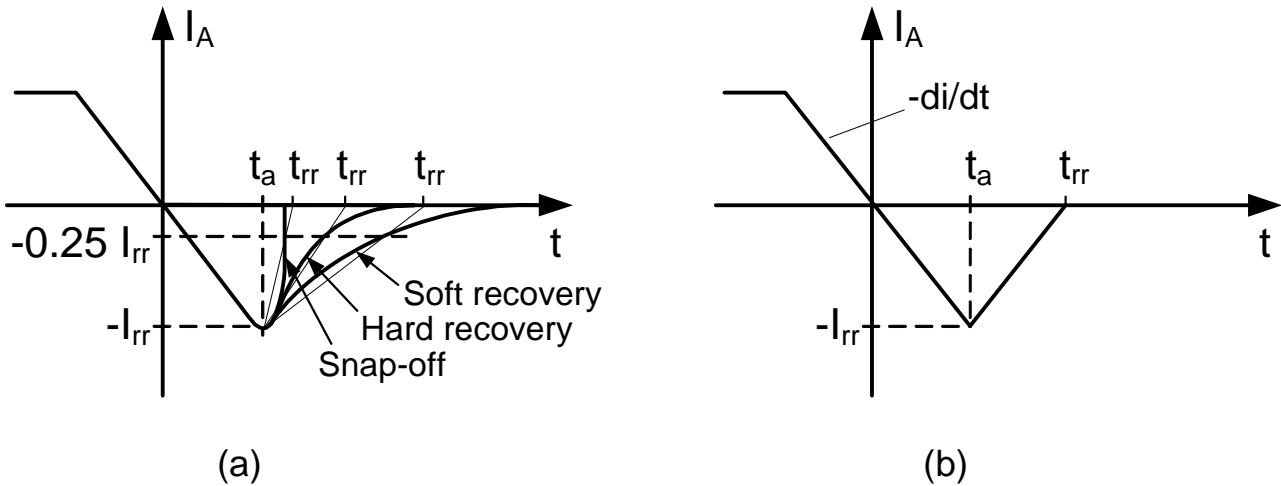

Fig 3 Types of reverse recovery waveforms (a) and simplification by a triangular model (b)

Phase control thyristors and rectifier diodes very often exhibit a soft recovery with  $s \sim 1.0$  or somewhat larger. If  $Q_{rr}$  and  $I_{rr}$  are known for a device, a rough confirmation of this can be easily found by assuming a triangular shape for the recovery current, as shown in Fig. 3 (b). Here,

$$s = \frac{2Q_{rr} di / dt}{I_{rr}^2} - 1. \quad E^{qn} 1$$

This equation is also a tool to verify if the data of  $Q_{rr}$  and  $I_{rr}$  given in a data sheet from a semiconductor supplier fit together. In many cases,  $s$  does not vary significantly over a considerable range of  $di/dt$  or junction temperature.

To obtain the reverse voltage overshoot  $V_{RM}$ , the current and voltage transients now have to be calculated, assuming a mathematically defined behavior for the reverse recovery current waveform. It is very common to utilize an exponentially decaying function for this purpose. An alternative procedure has been proposed [1], which includes the mathematically related hyperbolic *secant* function instead. Fig. 4 shows a comparison of the two approaches. In the following, the two possibilities will be discussed and compared.

[1] R. S. Chokhawala, E. I. Carroll, "A snubber design tool for P-N junction reverse recovery using a more accurate simulation of the reverse recovery waveform", IEEE Transactions on Industry Applications 27 #1, 74 (1991).

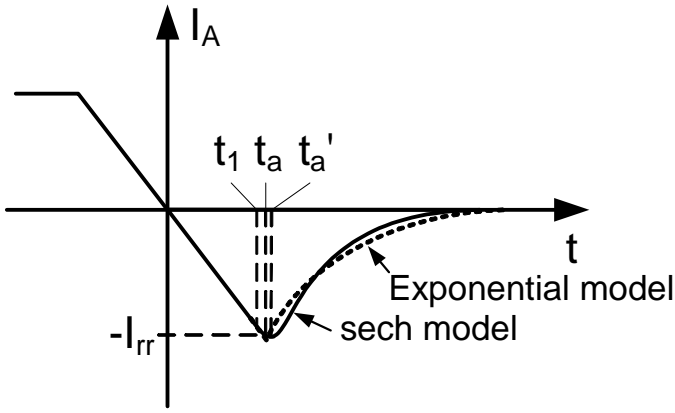

Fig 4 Comparison of exponential and sech models, adjusted to exhibit the same  $di/dt$ ,  $Q_{rr}$  and  $I_{rr}$

### 3.1 Exponential Recovery Current Model

As is visible in Fig. 4, the exponential current model assumes that the reverse current is linear up to  $t = t_a$  and  $I_A = -I_{rr}$  with a slope of  $-di/dt$  (as mentioned, "di/dt" is taken as a positive quantity in this paper, although mathematically it is negative), and it from then on decays with an exponential function:

$$I_A(t) = -I_{rr} e^{-\frac{t-t_a}{\tau}}, \quad E^{qn} 2$$

where  $\tau$  is the decay time constant.  $t_a$  is known from  $di/dt$  and  $I_{rr}$ , and  $\tau$  can be found by using  $Q_{rr}$ :

$$t = \frac{Q_{rr}}{I_{rr}} - \frac{I_{rr}}{2 \cdot di/dt}. \quad E^{qn} 3$$

The sharp  $di/dt$  reversal in the reverse current waveform of this model is not very harmful; it will induce a voltage step of the order of a few volts if there is non-zero stray inductance  $L_\sigma$  (of the order of 1  $\mu$ H) in the snubber circuit.

For semiconductor devices with a normal soft recovery and without extra tail currents, the approach of an exponential model is quite powerful and well suited to calculate the turn-off overvoltages.

### 3.2 Hyperbolic Secant Recovery Current Model

It has been proposed in [1] to replace the exponential function (2) by a hyperbolic secant function

$$I_A(t) = \begin{cases} -di/dt \cdot t, & t \leq t_1 \\ -I_{rr} \operatorname{sech} \frac{t-t_a'}{t}, & t > t_1 \end{cases}. \quad E^{qn} 4$$

This function creates a nicely rounded reverse recovery current peak, which is very similar to the measured transient in some cases, as will be seen in Fig. 6. The calculated reverse overvoltage will therefore be more accurate than that based on the above exponential model.

When attempting to define the function (4) from knowledge of  $di/dt$ ,  $Q_{rr}$  and  $I_{rr}$  by requiring a continuous function  $I_A(t)$  with a continuous derivative, we face a problem in some cases. The unknowns  $t_a'$  and  $t_1$  have to be obtained from (4) and its integral  $Q_{rr}$ . The corresponding transcendental equation though has no solution if  $s > 1.2$ , for the simple reason that the hyperbolic secant part of (4) never reaches the slope corresponding to  $di/dt$  if  $Q_{rr}$  is too large. In this case the hyperbolic secant part can be split into two different terms, one before and one after the reverse recovery current peak:

$$I_A(t) = \begin{cases} -di/dt \cdot t, & t \leq t_1 \\ -I_{rr} \operatorname{sech} \frac{t-t_a'}{t_a'}, & t_1 < t \leq t_a' \\ -I_{rr} \operatorname{sech} \frac{t-t_a'}{t_b}, & t > t_a' \end{cases} \quad E^{qn} 5$$

Now, we have one more degree of freedom, but we need to have one more input parameter beyond  $di/dt$ ,  $Q_{rr}$  and  $I_{rr}$ . We can either make assumptions and, for example, use the largest value of  $\tau_a$  still matching the slope of  $di/dt$  or by letting it satisfy some assumptions on  $t_a'$ . Investigating measured transients of different phase control device types has led us to the conclusion that both for soft and also for hard recovery ( $s < 0.8$  and  $s > 1.2$ ), finding a suitable model according to  $E^{qns}$ . (4) or (5) is often impractical, since it requires accurate knowledge of measured transients in order to add value.

### 3.3 Calculation of Reverse Overvoltage Peak

Depending on the degree of accuracy the circuit designer requires, he will utilize different approaches. If a very high accuracy is needed, it would be best to take an actual measurement of a reverse recovery transient and to parameterize it according to the above hyperbolic secant or exponential functions, using the  $Q_{rr}$  and  $I_{rr}$  values known for the semiconductor component under the expected operation conditions. The overvoltage waveform could then be calculated by using a circuit simulator like Pspice or by general calculation programs enabling the solution of differential equations. In Pspice, such a calculation circuit is quite easy to set up, as shown in Fig. 5. Fig. 6 gives a comparison of a measurement of the thyristor 5STP 18L4200 with the two models adjusted for equal  $di/dt$ ,  $Q_{rr}$  and  $I_{rr}$ . The sech model current transient is very similar to the measured one, and the calculated overvoltage curve is also close to the measured one. Only at times  $t > 80 \mu s$  does the measured voltage start to deviate which is caused by the circuit losing reverse voltage over longer times, whereas the simulation keeps the voltage constant at  $-800 V$ . The exponential model shows quite a difference from the measured behavior, both in the current and voltage waveforms.

As outlined above, it is questionable whether the cumbersome sech function should be used. Comparing a selection of turn-off transients of phase control thyristors and rectifier diodes has shown that when  $di/dt$ ,  $Q_{rr}$  and  $I_{rr}$  are used as input parameters, the differences in reverse overvoltage peak amplitude between the two models is often within  $\pm 10 \%$ . It should be noted though that in many cases, the exponential model tends to underestimate the reverse voltage peak.

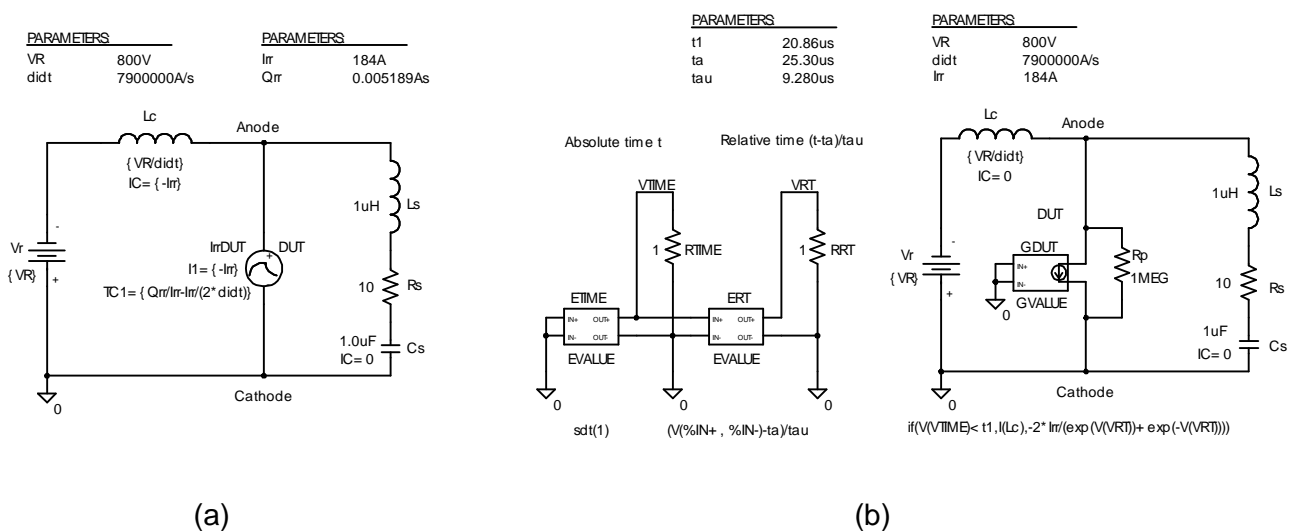

Fig 5 Pspice circuits for calculating reverse overvoltage, using the exponential (a) and the sech (b) models

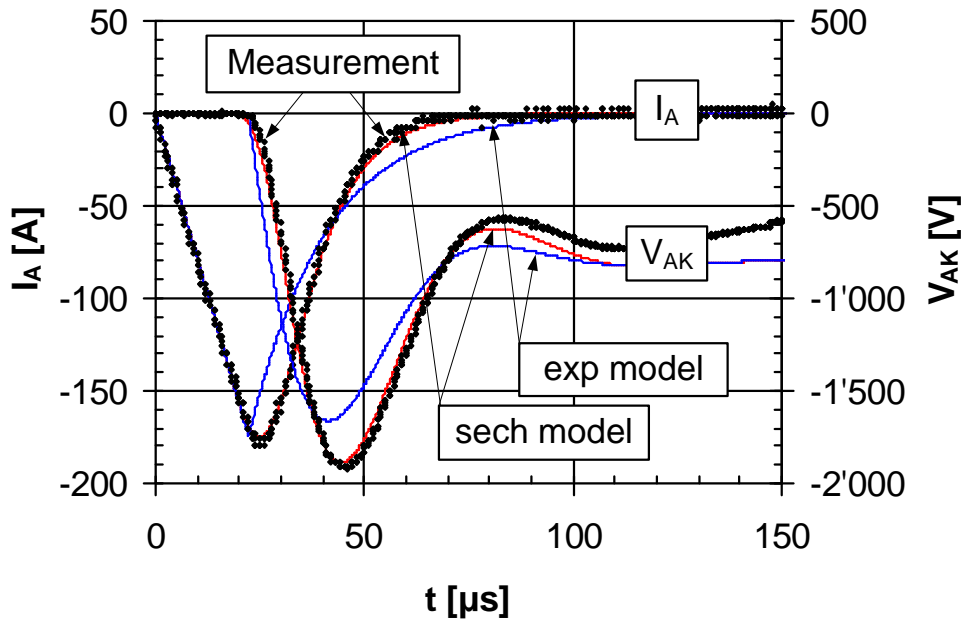

Fig 6 Turn-off transients for a 5STP 18L4200 thyristor at 125 °C and -7.9 A/μs with a snubber of 10 Ω/1.0 μF and a reverse voltage of about -800 V. The measured waveform is compared with model transients adjusted for equal di/dt, Q<sub>rr</sub> and I<sub>rr</sub>.

If a sufficiently large margin is provided, it is adequate to base the overvoltage calculation on Q<sub>rr</sub> only and thus to utilize the diagrams given in Fig. 7. These curves are based on experimental results with a wide range of components. The curves can be used as follows. It is assumed that the stationary voltage V<sub>R</sub> and the commutation inductance L<sub>c</sub> are known. The ratio V<sub>R</sub>/L<sub>c</sub> then gives the di/dt. From the thyristor or diode data sheet we read the Q<sub>rr</sub> value at this di/dt. Knowing the desired ratio V<sub>RM</sub>/V<sub>R</sub>, the minimum capacitance C<sub>s</sub> can then be found by reading Q<sub>rr</sub>/C<sub>s</sub>·V<sub>R</sub> at the maximum of the appropriate curve in Fig. 7. Since C<sub>s</sub> is known now, reading the value R<sub>s</sub><sup>2</sup>·C<sub>s</sub>/L<sub>c</sub> on the horizontal axis then yields the optimum value of R<sub>s</sub>.

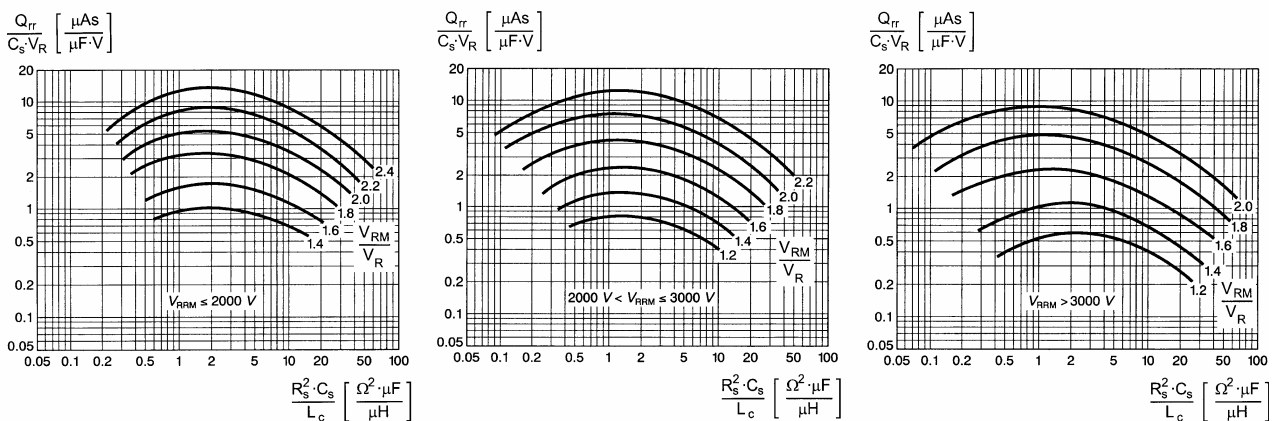

Fig 7 Curves for determining the optimum RC snubber values of ABB phase control thyristors. The curves are valid for thyristors with V<sub>RRM</sub> ratings below 2000 V (a), between 2000 and 3000 V (b) and above 3000 V (c). For diodes, similar curves apply but they depend somewhat more on the specifics of the design of the individual part number.

Besides the reverse overvoltage, the energy dissipated in the snubber resistor during semiconductor turn-off is equally important for the design of the circuit. As a rule of thumb, this value is typically of the order of the energy stored in the capacitor at V = V<sub>R</sub>, i.e.

$$E_{R_{soff}} \approx \frac{C_s}{2} V_R^2. \quad E^{qn} 6$$

For more accurate estimations, E<sub>R<sub>soff</sub></sub> can be easily extracted from the above mentioned simulations. Obviously, the simulation also delivers the turn-off energy E<sub>off</sub> dissipated in the semiconductor device.



## 4 Snubber Design for an Individual Semiconductor

An example for calculating the optimum snubber is given in the following. Thyristor 5STP 26N6500 is to be used at  $V_{RM} = 4700 \text{ V}$  and  $V_R = 2600 \text{ V}$ :  $V_{RM}/V_R$  is therefore 1.8. The commutation inductance is  $520 \mu\text{H}$ , so that  $di/dt$  is  $5 \text{ A}/\mu\text{s}$ . The data sheet now shows that the maximum  $Q_{rr}$  at  $125 \text{ }^\circ\text{C}$  is  $9000 \mu\text{As}$ . From Fig. 7 (c) the optimum value for  $C_s$ , corresponding to  $Q_{rr}/C_s \cdot V_R = 9 \mu\text{As}/\mu\text{F} \cdot \text{V}$ , is found to be  $C_s = 0.38 \mu\text{F}$ . From the horizontal axis of Fig. 7 (c),  $R_s^2 \cdot C_s/L_c = 1.1 \Omega^2 \cdot \mu\text{F}/\mu\text{H}$ , and thus  $R_s = 39 \Omega$ .

When simulation methods with one of the models are used, the problem of selecting  $Q_{rr} - I_{rr}$  pairs arises. It is generally not advisable to combine the maximum  $Q_{rr}$  with the minimum  $I_{rr}$  of the data sheet range because these combinations are unrealistic.

It is worth mentioning that, particularly at high  $di/dt$  and low acceptable overvoltage, a small snubber resistor may result from the above calculation. Depending on the geometrical snubber stray inductance and the internal inductance of the snubber components, this may lead to an excessive initial snubber discharge current when a thyristor is triggered from high voltage. If the resulting  $di/dt$  is too high, the thyristor will fail. Careful consideration of the  $di/dt$  in this case should therefore be taken, especially if the snubber has to discharge rapidly with a high repetition rate. This in practice means that the snubber resistor should not be too small.

In cases of very low  $di/dt$ , e.g. below  $1 \text{ A}/\mu\text{s}$ , the above calculation may lead to a very small snubber capacitor. Remembering the junction capacitance present in the semiconductor device, a snubber may not even be necessary. Measurements as well as simulations have shown though that in some cases a small snubber of the order of  $0.1 \mu\text{F}$  and  $47 \Omega$  is useful to prevent circuit oscillations during turn-off.

## 5 Snubber Action in 6-Pulse Converter Bridge Configuration

The following discussion will focus on thyristors rather than on diodes, because thyristors can be considered as a generalization of both device types. Obviously, the freedom in selecting firing angles with diodes is not available, and the overvoltage considerations for thyristor bridges with full firing angle control and diode bridges are thus somewhat different.

In applications such as AC switches, the thyristors have individual RC snubbers that do not interact with other RC snubbers at turn-off. For the common 6-pulse bridge configuration though, the RC snubbers will communicate with each other at turn-off, if each thyristor has its own RC snubber. Let us study the influence at turn-off of thyristor 1 in Fig. 8.

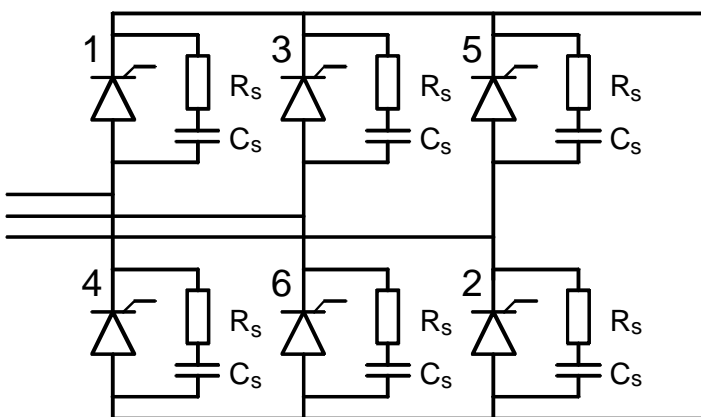

Fig 8 6-pulse thyristor converter bridge configuration with individual RC snubbers for each semiconductor

At turn-off of thyristor 1, thyristors 2 and 3 are conducting and are thus short-circuiting their RC snubbers but thyristors 4, 5 and 6 are blocking and thus their RC snubbers influence the turn-off of thyristor 1. For this turn-off phase we get an equivalent circuit as shown in Fig. 9.

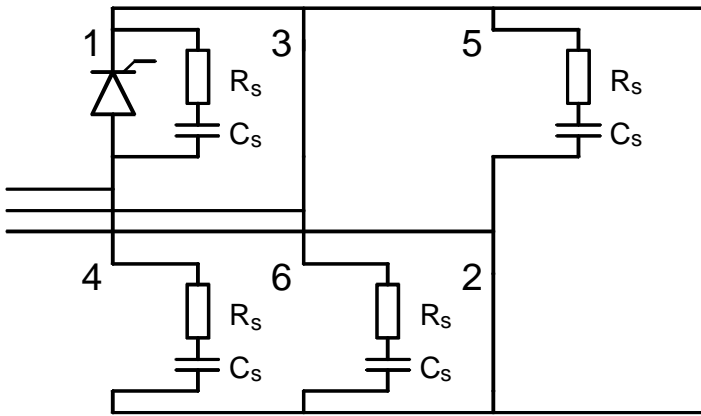

Fig 9 Equivalent circuit when thyristor 1 turns off

In Fig. 9 we see that the RC snubbers of thyristors 5 and 6 are now connected in parallel and this parallel connection is in series with the RC snubber of thyristor 4. Simplifying Fig. 9 we arrive at Fig. 10.

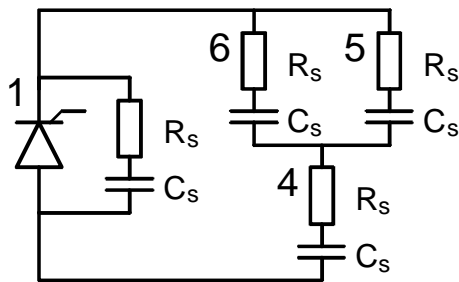

Fig 10 Simplified equivalent circuit during turn-off of thyristor 1

Using standard formulas for parallel and series connection of resistors and capacitors, we find that thyristor 1 at turn-off sees an RC snubber with equivalent resistance and capacitance  $R_{eq}$  and  $C_{eq}$  which can be expressed by the component values  $R_s$  and  $C_s$  as:

$$R_{eq} = \frac{3}{5} R_s \quad E^{qn} 7$$

and

$$C_{eq} = \frac{5}{3} C_s \quad E^{qn} 8$$

For the calculation of the overvoltage peak for 6-pulse bridges,  $R_{eq}$  and  $C_{eq}$  should therefore be used in the formulas and the discrete component values  $R_s$  and  $C_s$  can then be calculated from (7) and (8).

Due to the nature of the 6 pulse bridge the thyristor and the snubber circuit will see voltage spikes emanating from the commutation of the other thyristors in the bridge. The voltage spikes are depending on the firing angle and will be largest at a firing angle of  $90^\circ$ . Thyristor 1, for example, will in addition to its own turn-on and turn-off also see overvoltage spikes from the turn-off of thyristors 3, 4 and 6. The voltage spikes from turn-off of 4 and 6 will though not affect the voltage stress of the thyristor, since they appear at low voltage levels. The turn-off of thyristor 3 will not affect the voltage stress of the device either, but it has a significant impact on the RC-snubber losses.

---

## 6 Snubber Component Selection

In the earlier paragraphs it was shown how the resistance and capacitance values for the RC snubber can be determined. The calculated values can though seldom be directly realized with real components. To reduce costs, standard components are normally selected and they are available only in certain steps and with certain tolerances. Since the resistors often are available in finer steps than the capacitors, we recommend determining the capacitance value first. The capacitance is chosen as the standard value the supplier offers and which is the closest to the calculated capacitance, having in mind that a higher capacitance value gives a higher safety margin at the cost of higher resistor losses and that a lower value, considering also the component tolerances, gives a higher voltage peak than that calculated. By selecting a capacitance other than that which is calculated, the ratio  $R_s^2 \cdot C_s / L_c$  is changed and therefore a check should be made as to whether a different resistance value should be chosen to minimize the overvoltage. The calculated resistance is then chosen as the closest available standard value. The difference in overvoltage resulting from selecting a resistance slightly different from the calculated one can normally be disregarded.

To decide on the real components though, more information other than just the capacitance and the resistance is needed and this paragraph gives some recommendations on how to select the real devices needed to achieve a successful RC snubber operation. The importance of careful selection of the snubber resistors and capacitors should not be underestimated and we therefore recommend the use of documentation, sales support and, where available, software tools which the resistor and capacitor suppliers can provide.

### 6.1 Voltage Ratings of Snubber Capacitor and Snubber Resistor

When selecting the capacitor, a number of different voltage ratings have to be considered. The main parameters are the rms and the repetitive voltage ratings. The rms voltage the capacitor sees is dependent on the application and on the way it is used. For a 6-pulse bridge, the rms voltage will be a function of the firing angle. It reaches its maximum for firing angles of  $0^\circ$  or  $180^\circ$  at 0.90 times the sinusoidal rms voltage at the 3-phase input of the bridge. Some capacitor suppliers do not rate their capacitors with an rms current but either with a "rated" AC voltage, which is then defined as either the maximum repetitive peak voltage in operation or as the maximum repetitive peak-to-peak voltage. Peak voltages for this consideration do not include the relatively short transient switching overvoltages discussed above.

It is important to consider the switching overvoltages separately. Capacitor suppliers often specify the real peak voltage limit as a function of the percentage of time this voltage is applied with respect to the repetition time period.

The reliability of the capacitor depends on a number of parameters such as voltage utilization, ambient temperature and self-heating due to the series resistance and dielectric loss in connection with thermal resistance. The lifetime expectancy as function of the applied voltage is sometimes given by the capacitor suppliers. In cases where this information is no available, it is recommended to avoid using the capacitor above 70 % of its rated voltage.

The ambient temperature together with the internal losses and the thermal resistance must also be considered for the life expectancy. As an approximation, it can be assumed that the lifetime is reduced by a factor of 2 for every  $10^\circ\text{C}$  that the so-called "hot spot temperature" in the capacitor increases. Most suppliers though present life expectancy curves and these should be consulted for capacitor selection. The hot spot temperature  $T_{hs}$  can be calculated by:

$$T_{hs} = T_a + (P_d + P_c)R_{thha}, \quad \text{E}^{qn} 9$$

where  $P_d$  is the dielectric power loss,  $P_c$  the power loss due to series resistance  $R_{ser}$ , and  $R_{thha}$  is the thermal resistance from hot spot to ambient.  $P_d$  and  $P_c$  can be obtained from:

$$P_d = p \cdot C \cdot U_{pp}^2 \cdot f \cdot \frac{\tan d_{diel}}{4} \quad \text{and} \quad \text{E}^{qn} 10$$

$$P_c = R_{ser} I_{rms}^2, \quad \text{E}^{qn} 11$$

where  $U_{pp}$  is the full peak-to-peak voltage the capacitor experiences,  $f$  is the repetition frequency, and  $\tan \delta_{\text{diel}}$  is the dielectric loss factor of the capacitor. The input parameters for this calculation are given in the capacitor data sheets. The hot-spot temperature must be made to be lower than the rated maximum temperature for the capacitor. If this is not the case, the ambient temperature may have to be reduced, the capacitor may have to be cooled or two capacitors in parallel may be needed.

Other parameters that are critical for capacitor selection are the peak and the rms current ratings. The peak current rating  $I_{\text{peak}}$  defines the maximum  $dv/dt$  that can be applied repetitively to the capacitor:

$$dv/dt = \frac{I_{\text{peak}}}{C}. \quad \text{E}^{\text{qn}} 12$$

Besides the thermal effects in the capacitor as discussed above, the rms current through the capacitor also has to be below a given limit to avoid problems with, for instance, *fast-on* terminals.

Since the ambient temperature has a high impact on capacitor reliability, we recommend a mechanical design such that the capacitor is not additionally heated by resistors or semiconductors such as through adjacent placement or through hot air flow from heat sinks. Although the power loss generated in the capacitor is by far smaller than that in the resistor and the semiconductor, ample cooling paths should be provided.

## 6.2 Power Rating of Snubber Resistor

Using the over voltage calculation above, the resistance value for the snubber resistor is calculated and it is then fairly simple to calculate the energy dissipated in the resistor during thyristor turn-off. This information alone is not sufficient to define the appropriate resistor.

To calculate the total power loss of the resistor, an analysis of the total operation cycle is needed. If we look at one cycle for Thyristor 1 in the above 6-pulse bridge, we see that the capacitor will be completely discharged at turn-on of Thyristor 1 (snubber energy loss  $E_{R_{\text{son}}}$ ) and re-charged at turn-off of Thyristor 1 (snubber energy loss  $E_{R_{\text{soff}}}$ ). The turn-on snubber energy, dissipated in the resistor, is

$$E_{R_{\text{son}}} = \frac{C}{2} V_c^2, \quad \text{E}^{\text{qn}} 13$$

where  $V_c$  is the actual charging voltage of the snubber capacitor.  $E_{R_{\text{soff}}}$  is of the same order of magnitude or somewhat larger. At turn-off of Thyristor 3, the voltage across the RC snubber for Thyristor 1 will change polarity thus causing a further dissipation of approximately  $E_{R_{\text{son}}}$ . At turn-off of Thyristors 4 and 6, the RC snubber for Thyristor 1 will support the RC snubbers as described above causing yet another dissipation, which for simplicity is often again approximated by  $E_{R_{\text{son}}}$ . At turn-off of Thyristor 2, Thyristor 1 is conducting, so the RC snubber is shorted and no power loss will be dissipated in the snubber resistor of Thyristor 1. The total dissipation during one cycle will thus be approximately:

$$E_{\text{cycle}} \cong 2 \cdot (E_{R_{\text{soff}}} + E_{R_{\text{son}}}) \cong 2 \cdot C \cdot V_c^2, \quad \text{E}^{\text{qn}} 14$$

where  $V_c$  is the commutation voltage, which can be expressed as:

$$V_c = \sqrt{2} \cdot U \cdot \sin a, \quad \text{E}^{\text{qn}} 15$$

where  $U$  is the 3-phase rms supply voltage and  $\alpha$  the firing angle. The power loss in the resistor can then be calculated from (14). The power loss is strongly dependent on the firing angle, and for optimization of the resistor we recommend a study of the expected operation modes.

---

For several reasons, it is generally not advisable to select a resistor with a rated power equal to the calculated maximum power loss. Many resistor suppliers rate the maximum power such that a surface temperature of up to 350 °C results, which can be too high for the adjacent components. The reliability of the device is additionally affected by the high temperature, especially if the power loss and therefore the surface temperature, changes frequently between cold and hot. Recommendations in reliability literature suggest using a resistor up to a maximum of 60 % of its power rating to get a reasonable lifetime for the component. Low-inductance resistors with bifilar windings are recommended to be used up to a maximum of 50 % of their rating. For ambient temperatures above 60 °C, further reduction of the power utilization is recommended.

For some applications, the power rating of the resistor can be even better optimized by considering the duration of the power dissipation. One example is the 6-pulse bridge, used as a rectifier for AC drives. In this application, the rectifier is run at high firing angles only during short times when the DC-link capacitor is charged. Otherwise, the rectifier is run at low firing angles, and the power rating of the resistor can therefore be chosen lower than for a rectifier that has to operate at high firing angles continuously. The amount of rated power reduction depends on the thermal time constants of the resistor.

Other aspects to consider for resistor selection are the internal inductance and the mechanical design. To avoid oscillations and to increase the efficiency of the RC snubber, resistors of low inductance type are recommended. The layout should be chosen such as to avoid unnecessary inductance in the cabling between the RC snubber components and the semiconductor. The mechanical design of the resistor should allow for efficient cooling by water or air, depending on power dissipation and space availability.

## 7 Conclusions

We have shown that RC snubber networks can be utilized to limit the reverse overvoltage during turn-off of phase control thyristors or rectifier diodes. They also have an influence on the power loss in the semiconductor but they cause losses of their own due to the need to discharge the capacitor before the next semiconductor turn-off. Design and snubber component selection, also for 6-pulse bridge design, have been discussed in detail. The additional snubber requirement in case of series connection of semiconductor devices has not been discussed and is topic by itself.

We have also shown that by using reliable test or specification data of  $Q_{rr}$  and  $I_{rr}$  at a given  $di/dt$ , models for the reverse current waveform can be set up and will allow more accurate calculation of the reverse overvoltage peak amplitude, the snubber energy loss and the semiconductor turn-off loss.

## 8 Additional notes

### 8.1 References

- 1) IEC 60747 "Semiconductor Devices"
- 2) 5SYA2055 "Switching losses for phase control and bi-directionally controlled thyristors"

The application note, Reference 2, is available at [www.abb.com/semiconductors](http://www.abb.com/semiconductors)

---

## 8.2 Application support

For further information please contact:

Product marketing engineer:

Björn Backlund

Phone +41 58 5861 330, fax +41 58 5861 306

e-mail [bjorn.backlund@ch.abb.com](mailto:bjorn.backlund@ch.abb.com)

Address:

**ABB Switzerland Ltd**

**Semiconductors**

Fabrikstrasse 3

CH-5600 Lenzburg

Switzerland

E-Mail [abbsem@ch.abb.com](mailto:abbsem@ch.abb.com)

Internet [www.abb.com/semiconductors](http://www.abb.com/semiconductors)

Data sheets for the devices and your nearest sales office can be found at the ABB Switzerland Ltd, Semiconductors internet web site:

[http:// www.abb.com/semiconductors](http://www.abb.com/semiconductors)