

12.6 KA / 20 KV / 300 HZ REVERSE CONDUCTING SOLID STATE CLOSING SWITCH FOR DE-NOX / DE-SOX MODULATOR

A. Welleman, S. Gekenidis

ABB Switzerland Ltd, Semiconductors

Fabrikstrasse 3, CH-5600 Lenzburg, Switzerland

Abstract

The presentation will discuss the specification, the design, the construction and the test results of a solid state switch which is used in De-NOx / De-SOx modulators. The closing switch is operating at a charge voltage of 20 kVdc with a 300 Hz pulse repetition rate and a 12.6 kA, 12 μ s exponential decay waveform. In case of arcing in the load the waveform will change to a 250 μ s damped sine wave. The current rise rate is in excess of 10 kA/ μ s or more. The paper will show the selection criteria of the semiconductor devices, and the optimization of the devices for this application. The complete ready-to-use switch is built-up with a series connection of eight reverse conducting devices with individual driver units which are optical triggered. This construction results in compact stack with very low self inductance. The switch is capable to operate continuous at a pulse repetition rate of 300 Hz and can be cooled by transformer oil or de-ionized water. Information will also be given on reliability and life expectancy based on tests and earlier produced switches.

I. INTRODUCTION

Solid state switches are successfully replacing now thyatrons and ignitrons as the performance is increasing the experience is getting larger and more optimized components are getting available. The switching technology presented in this paper is a product which was developed in 2002 and finally reach a breakthrough in radar power supplies for civil airports and environmental applications like De-NOx and De-SOx modulators as here described. ABB has developed optimized semiconductor components which can handle the continuously high power which is needed in this field combined with a very high reliability. The paper will show the application requirements, the specification of the switch, the selection of the components, the built-up of the stack assembly and finally the application oriented test which is done under nominal and under fault conditions (Arcing in the load).

II. APPLICATION

The switch is designed for a modulator with using a 1:10 step-up pulse transformer. In Figure 1 the circuit

diagram of the modulator is shown. As this paper will describe the pulse power switch only, no further information about the modulator specification will be given.

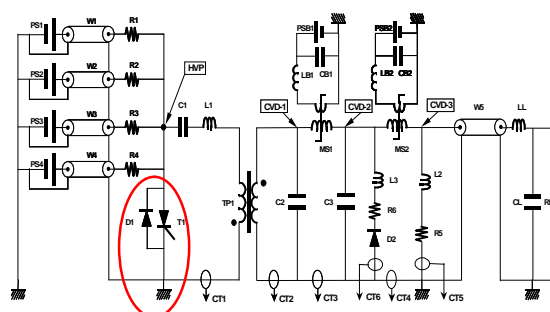

Figure 1. Circuit Diagram Modulator with the reverse conducting solid state switch.

III. SWITCH SPECIFICATION

Based on the requirements in the application a switch was specified which could handle the high di/dt, the current and the reliability. The switch is used in air but the cooling is done by pumping oil trough heat sinks between the semiconductor components. The oil is available from the high voltage 200kV part of the modulator, which is built in an oil tank. In Table 1 the basic specification of the switch is shown.

Charge Voltage	20 kVdc
Peak Current (normal)	12.6 kA, Exponential decay
Current rate of rise (di/dt)	10 kA/ μ s
Pulse duration (normal)	10 μ s
Peak Current (arcing)	12.6 kA, Damped sine wave
Pulse duration (arcing)	250 μ s
Pulse Repetition Rate	300 Hz
Cooling method	Transformer Oil

Table 1. Solid State Switch basic specification.

IV. COMPONENT SELECTION

To reach the specification above and to get a good reliability several factors play a rule by selecting the

semiconductor device. Thyristor devices are not capable to handle the high di/dt values. As we do not need to switch-off the devices there is no need for IGCT or IGBT, which means that finally the so called discharge devices are left. Discharge devices are based on IGCT technology but have optimized turn-on behavior and are combined with optimized driver units for turn-on only. Discharge devices are not capable to switch-off a current. In figure 2 the wafers of IGBT, Thyristor and a discharge device are shown. Together with a very low inductive housing and combining a monolithic integrated freewheeling diode on the same silicon wafer, the product is still using standard mass production parts which are benefitting from very high reliability and excellent quality standards. Finally the driver unit will be mounted to the device, and because of the very low inductive path, the device will have improved switch-on behavior. The driver units are designed to be used in series connection by means of an inductive coupling with a current source power supply [1]. The isolation between the device levels is given by a 30kV, HV closed loop cable from a current source power supply.

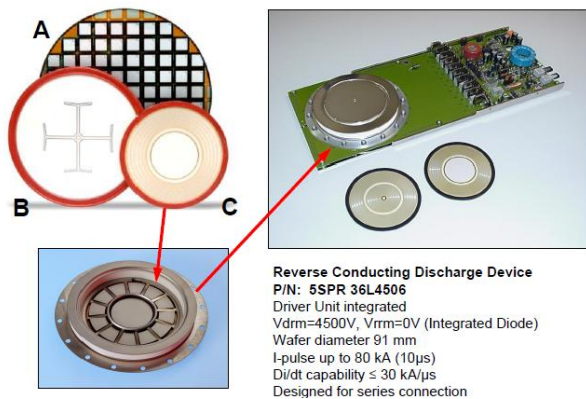

Figure 2. Selection of Silicon Wafers
A) IGBT Dies B) Thyristor Wafer C) GCT wafer

The device selected for the switch assembly is the ABB P/N 5SPR 26L4506 which is a reverse conducting device with forward blocking voltage of 4.5 kV and with an monolithic integrated freewheeling diode in the middle of the 91 mm wafer. This integrated diode is needed in case the load is arcing and the wave form will change from exponential decay into a damped sine wave. The wafer is basically a GCT wafer but optimized for fast turn-on in discharge applications. The low inductive housing with ring gate structure is a standard IGCT housing.

V. SWITCH ASSEMBLY DESIGN

As specified in Table 1 the switch is designed for a working (charge) voltage of 20kVdc. The device 5SPR 26L4506 has a blocking voltage of 4.5kV and therefore

series connection of devices is needed. For reliability reasons we have to take cosmic ray into consideration which means that we can charge max. 2.8kVdc to each device level. The result will be 7 devices in series for 20kVdc, but as there should be at least one device redundancy, it was decided to go for 8 devices in series connection. In case of failure the device will fail in short circuit mode which means that the remaining devices have still the blocking capability to keep the switch operating. An optical output signal is indicating which device has failed in the switch. To enable easy series connection the driver units of the devices have round input transformers for inductive coupling with a closed loop current source power supply. The energy is transferred through a HV cable which gives the isolation between the different driver units. The current capability of the 91 mm device is sufficient to handle the 12.6kA @ 10µs, no parallel connection is needed. The losses per pulse will be in the range of 6 Joule and because of the 300Hz pulse repetition rate there will be losses in the range of 180W per device. To avoid overheating of the assembly with 8 devices active cooling must be implemented. Low inductance is important in this application and therefore the stack should be designed as compact as possible which can be reached with water or oil cooling. The fluid cooling is better as forced air cooling because of smaller heat sinks. Cooling oil was already available in the system, the modulator manufacturer has specified oil cooling for the switch assembly. To energize the driver units a current source power supply is needed. This is a current source power supply with an output of 25kHz / 8A. The supplied power is sufficient to energize the 8 driver units which are used at 300 Hz pulse repetition rate.

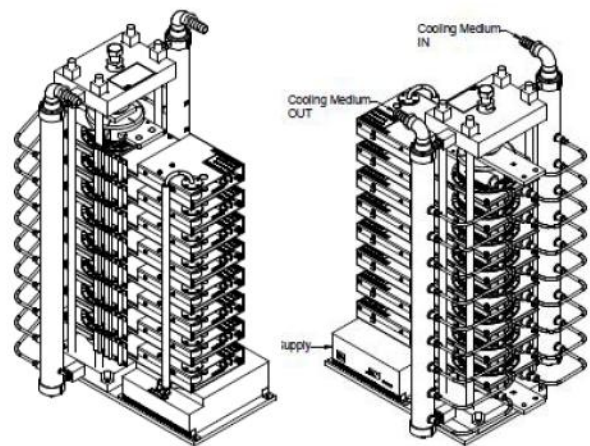

Figure 3. Design Switch Assembly 5SVC083607E03

The assembly is built in a fully isolated clamping system made from glass fiber epoxy and the devices are clamped by a Bellville spring pressure pack with 40kN force. The weight of the complete assembly including the power

supply is approx. 60 kg. The overall dimensions are H=830 mm, W=430 mm, D=480 mm. The cooling is done by transformer oil and individual heat sinks per device. There are two stainless steel manifolds which distribute coolant through FEP tubes to the heat sinks. The recommended oil flow for the complete assembly is 26 liters per minute. In Figure 4 the circuit diagram and specific main components are shown.

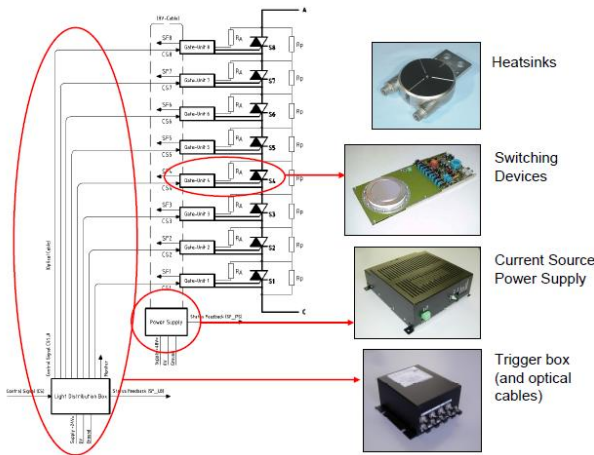

Figure 4. Circuit diagram and assembly main parts

The switch needs an optical signal to be triggered. The trigger signal is received by the trigger box, which is an optical distribution box with one input and eight optical outputs, one to each driver unit. An additional trigger output is available for monitoring purpose. Because the devices cannot switch-off any current the trigger signal has to be on the driver unit till the energy is completely discharged from the system. As the pulse length in fault condition can reach 250 μ s, the optical trigger signal to the driver unit is given for a fixed 500 μ s to make sure that the trigger pulse is sufficient long. In case the trigger pulse is too short, the semiconductor device will try to switch-off and can be damaged. In figure 5 the gate trigger pulse is shown.

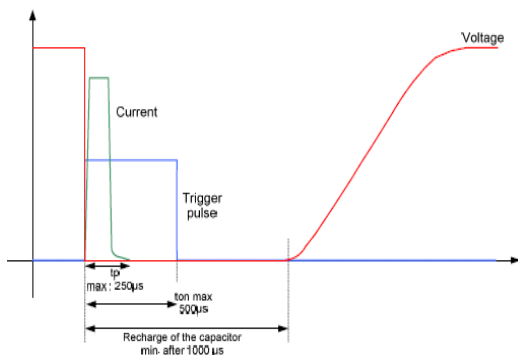

Figure 5. Length of trigger signal to switch

VI. TESTS

A. Component test

During the manufacturing process of the semiconductor components there are several in-line quality steps which are monitoring the production processes. After this a routine test with fixed electrical parameters and set values has to be passed and will be protocolized. The test results are delivered with the products to the end user, in this case with the stack assembly. The test reports are also important for the series connection to match the devices as good as possible. Some of the important parameters which are measured and recorded are leakage current and switch-on delay time, which is important for this application.

B. Switch assembly test

After the tested devices are built in to the assembly, the further tests will be application oriented. In Figure 6 the test circuit is shown.

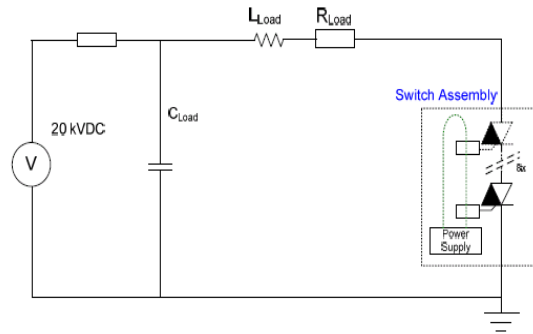

Figure 6. Test circuit of switch assembly

Nr.	Test	Conditions	Limits
1)	Blocking voltage test on device level	$V_{DR} = 4.0$ kV, sinus halve wave, 50 Hz Without parallel resistors $T_J = 25^\circ\text{C}$	$I_{DR} < 10$ mA
2)	Voltage sharing	$V_{dc_Switch} = 20$ kV DC $T_J = 25^\circ\text{C}$	Maximum difference $V_{AK\ S1} \dots V_{AK\ S8} = 400\text{V}$
3)	Difference of gate voltage delay of the 8 semiconductors	Turn on $V_{GK} = 5$ V $T_J = 25^\circ\text{C}$	Maximum difference of gate voltage delay = 50 ns
4)	Functional pulse test	R-L-C circuit Single pulse $V_{Switch} = 20$ kV $I_{Switch} > 12.6$ kA $R = 1.5$ Ω $L = 2$ μH $C = 290$ μF $T_a = 25^\circ\text{C}$	Go / No go
5)	Isolation test (Between Anode, Cathode and the 48 VDC input of the inductive power supply)	$V_{iso} = 40$ kV DC / 1 min. $T_a = 25^\circ\text{C}$	$I_{iso} < 1$ mA

Table 2. Test parameters and conditions

The tests are made in the Pulse Power Lab of ABB and the results are protocolized in detail for every assembly. Charge voltage and pulse current is measured in three different steps ramping up till application level. For the

charge voltage these steps are 10 – 15 and 20 kVdc, for the current 6.5 – 9.8 and 13 kA was selected. These tests are done at single pulse level because the power supply in the test circuit is not able to deliver the power for 300 Hz operation. The voltage and current wave form of the mentioned test are shown in figure 7.

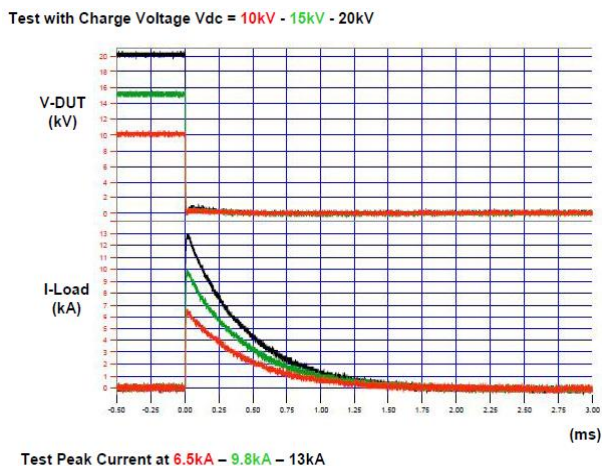

Figure 7. Voltage and Current during pulse test

VII. RELIABILITY

If not taken care, reliability can be an issue for high current repetitive pulse power applications. Notwithstanding better performance as thyratrons, also the semiconductor devices do not have infinite life. Therefore the design of high current repetitive switches has to be done very careful and needs the experience of the semiconductor manufacturer who knows the capability of the devices. Important parameters are the cosmic ray withstand ability (number of series devices) the peak current (wafer size, or parallel devices) the current rise rate (gate structure of wafer) the pulse repetition rate (thermal management) and the required lifetime in amount of pulses or in years. ABB has made for the device 5SPR 26L4506, which is used in this application, several long term tests under different conditions. One severe long term test was done with $I_p=31kA @ t_p=100\mu s$ [2] during over more than one million pulses. After analyzing the wafers of these devices it could be concluded that less than half of the life time was consumed. The devices in the presented application will only see 12.6kA @ 12 μs which is approx. 400x less stress condition as the tested devices. Also by analyzing the wafers from the De-NOx / De-SOx prototype switch, which was in use during 4 years we could not find serious wear-off at the contact fingers on the wafer. This proves that the design used is capable to work under the specified conditions during more than 12 years before replacement is expected to be needed. In figure 8 the contact fingers of the analyzed wafers from the prototype switch are shown.

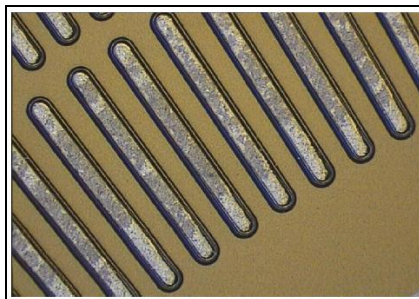

Figure 8. Contact fingers of wafers used in prototype switch after 4 years under application condition use.

VIII. FINAL PRODUCT

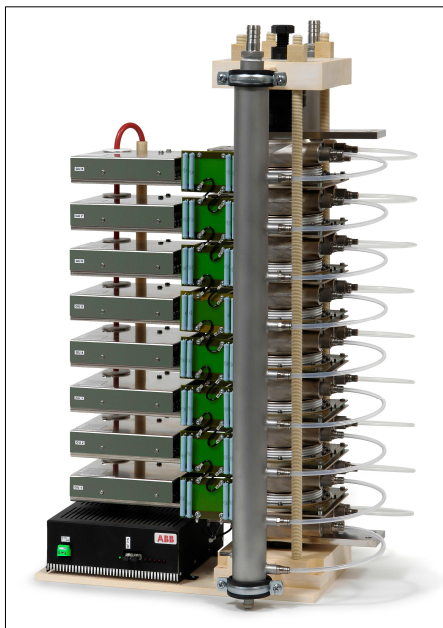

Figure 9. Picture of the complete modulator switch assembly (without triggerbox)

34 switches as presented are supplied to South Korea for use in modulators to clean the emission of a large steel sintering plant. The commissioning of the complete system is done in 2009.

IX. CONCLUSIONS

It has been shown that properly designed high power solid state switches are now becoming also successful in Industrial and Environmental applications. Years of experience with applications in the field and several tests have proven that reliability is at a very high level. System cost is almost comparable to tube driven designs, but operation cost for the solid state version is clearly less. The ABB Semiconductor group has successfully supplied

more than 400 switch assemblies for high power pulse modulators during the last 4 years and gained very large experience in military as well as industrial applications.

X. REFERENCES

[1] A.Welleman, "Semiconductor Switches are successfully replacing Thyratrons in demanding applications", 1st EAPPC2006, Chengdu, China, Sept. 2006.

[2] A. Welleman, R. Leutwyler, S. Gekenidis, "Design and Reliability of a High Voltage, High Current Solid State Switch for Magnetic Forming", 2nd Euro-Asia Pulse Power Conference 2nd EAPPC2008, Vilnius, Lithuania, Sept. 2008.

FOR FURTHER INFORMATION PLEASE CONTACT:

World Wide:

ABB Switzerland Ltd, Semiconductors

Fabrikstrasse 3

CH-5600 Lenzburg / Switzerland

Adriaan Welleman (adriaan.welleman@ch.abb.com)

For USA and Canada:

5S Components Inc. (formerly ABB)

630, Fifth Avenue

East McKeesport, PA 15053, USA

Kenny Stephenson (Kenny@5Scomponents.com)